

Hatching Egg Sanitizers

The "ELIMINATOR" Series

*Combining stainless steel technology with PVC economy,
we provide to the world's poultry industry
the best engineered, most reliable and most cost effective
Hatching Egg Sanitizers available*

← 3.000" →



The Sign for Quality

"WHERE THE SUM OF THE PARTS ALWAYS EQUALS THE WHOLE"

Q + U + A + L + I + T + Y = QUALITY

The only egg sanitizer engineered from the inside out

INTERNATIONAL A.I., INC. 7909 S. FAIRFAX • BLOOMINGTON, IN 47401
1-800-274-2824 • 812-824-2473 • FAX 812-824-2723

The “ELIMINATOR” Series ---

Did you know that International A.I., Inc., . . .

- was the first company to offer digital temperature control technology on Hatching Egg Sanitizers?
- was the first to offer the “split open” design of Hatching Egg Sanitizers?
- was the first to offer stainless steel heaters as a standard feature?
- was the first to use stainless steel pumps?
- is the first to offer models constructed of both stainless steel and/or welded PVC?
- is the first to offer conveyor tracks of both the “open” and the “flat wire” system?
- is the first to offer a cost effective cleaning solution not based on chlorine, but using a balanced **pH wash** to eliminate harmful bacteria?

We may not be as well known, we may not be the largest, but we do sell the best. Where others follow, we often break new ground. By listening to our customers, we consistently produce equipment designed to work for you — eliminating your high labor cost, eliminating high “cracked egg” numbers and eliminating destructive bacteria that reduces hatch. We help to eliminate the undesirable factors of egg sanitation that can result in lower hatches. We offer the “ELIMINATOR” series of Hatching Egg Sanitizers.

Engineered, constructed and developed to meet your needs, with quality to last for the next generation, we build and design our equipment as if we were going to use it for our own production. **Make it sturdy, make it reliable** and most of all, if it does fail, make it quick to diagnose and easy to fix! Down time costs money.

Our “**surround spray**” system has been engineered into each of our sanitizers. This system places the spray nozzles at the proper distance from your egg flats — top and bottom — to create a “chambered wall” of disinfectant spray that your eggs must travel through. Every egg, every time will be totally engulfed with the wash liquid. Our “**cone spray**” quat nozzles — one placed directly over each row of eggs — both rinse and apply the final sanitation solution. By using a true “cone type” nozzle, we eliminate the need for a third chamber. To reduce the quat from entering the wash chamber, **we cover our conveyor chain under these nozzles** so as not to spray onto the chain re-entering the wash chamber.

For the multiple user, we have matched our pumps and heaters to be interchangeable between models. We don’t just throw on any pump. We size our nozzles to the pump’s output, so not to overwork or underwork these pumps, providing years of trouble-free operation — a complete package, designed to work together.

All of our features, from “surround spray” wash, “cone spray” quat nozzles, out-of-harms’-way rear-mounted waterproof electrical connections, rear hinged top, simple and reliable relay logic control panel, to stainless steel heaters and pumps, all found within our “ELIMINATOR” series of Hatching Egg Sanitizers/Washers, are, and were designed for the rigorous demands of every day use, on the farm or in the hatchery. Engineered to match flock size and egg volume, to water supply and conveyor speed, with eggs exposure time to sanitizing solution. These Sanitizers are well “thought out” machines. Combining stainless steel technology with PVC economy, we provide to the world’s poultry industry the best engineered, most reliable and most cost effective Hatching Egg Sanitizers available. Working for you today, built to last for the next generation. International A.I., Inc. may not have reinvented the wheel, but we do build a better mouse trap!



Bradley S. Blume
President

ELIMINATE LABOR

“Eliminate” that extra person in your egg room with the purchase on an International A.I., Inc. Hatching Egg Sanitizer. Be more efficient by letting your egg gatherers “load” your eggs directly into our Sanitizer. When you collect directly onto your setting flats, you will not have to handle your eggs individually again after they have been sanitized, thus eliminating that extra labor while reducing your chance of cracks. You not only sanitize your hatching eggs, but also the flats themselves. With a reduction in both labor costs and number of cracks — along with the possible increase in hatch — **our Hatching Egg Sanitizers will help to increase your profits immediately.**

These Sanitizers will immediately reduce your egg room labor cost. So it’s up to you. This season, you can continue to pay for that extra egg room labor, and continue to pay that labor cost year after year. Or, you can apply that reduction in labor cost to the purchase of one of our Sanitizers. By using our payment/labor chart, you will see that our Sanitizers WILL NOT cost you any revenue. By applying your savings of labor towards the purchase price, you can see for yourself, your overhead will not be increased, and actually, if you apply your savings correctly, you can decrease your overall costs and still pay for this purchase. Afterwards, this will also be your weekly savings. Think about this: You could save \$12,000 next year on labor cost reduction. After five years this it adds up to \$60,000 in savings! If you have been using an Aqua-Magic system for the last five years, that’s \$60,000 you spent needlessly. What possible reason can you have for not taking an action that will put these savings back into your pockets, year after year?

CHEMICAL METERING PUMP pH



Metering Pump

Alarm for low pH levels

- Pilot lights on functions
- Fully automatic
- Maintains proper pH level
- Uses enclosed “egg caps”



“Egg caps”

- No physical handling of powder
- Installs into hopper
- The safest system available
- Powder or liquid available

For our complete line of Sanitation Chemicals see our supplementary brochure. We offer a full range of disinfectant products for the Hatchery and the Breeder Farm operations.

ELIMINATOR 1

All photos show right-hand machines

8

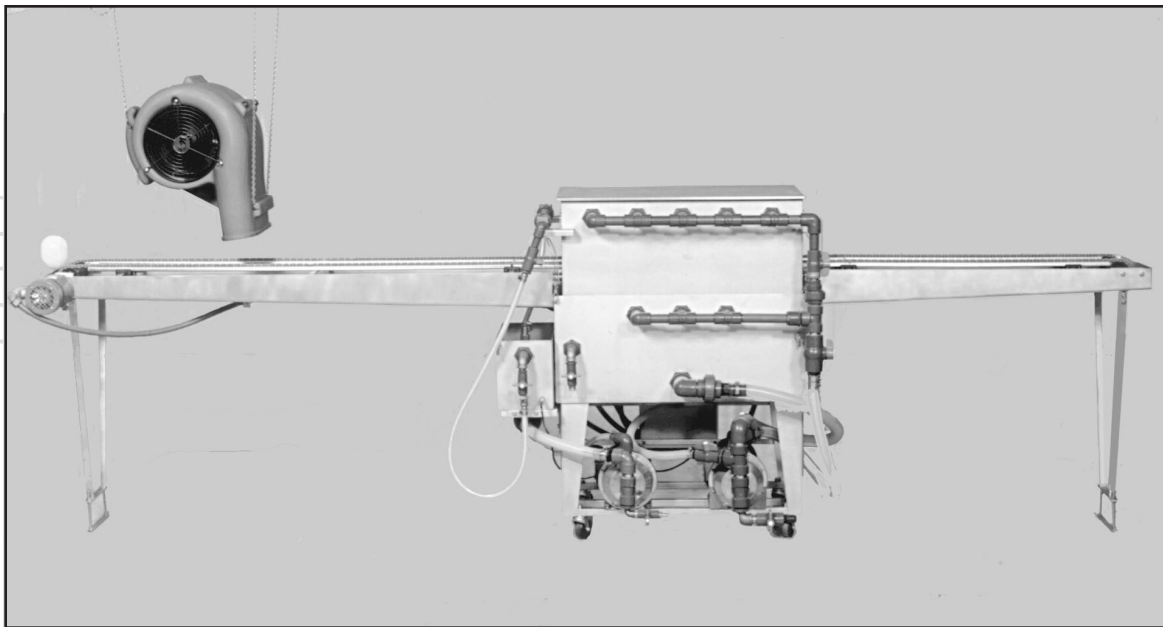

- Stainless steel construction • 15,000 to 25,000 breeders •
- 8,600 turkey/12,500 broiler/breeders eggs per hour •
- Standard model up to 13" (15 cm) flats • 4' incoming/6' outgoing conveyors •
- Wide track available accepts flats up to 24" (26 cm) wide •

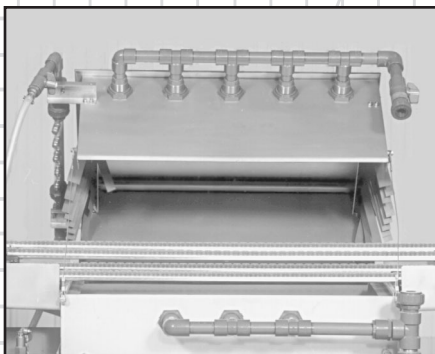

- Our exclusive rear-hinged top
- Easy access

- Our exclusive top hinge
- Easy access

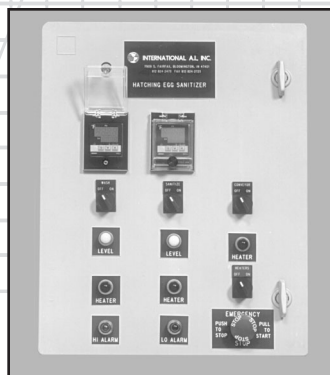
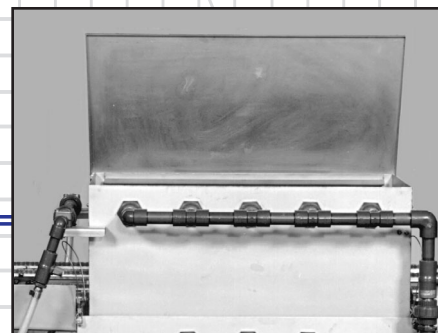

- Control panel
- Mount where you please
- Uses relay logic that is very simple and very reliable
- Pilot lights on all functions that diagnose outputs and operations

ELIMINATOR 1

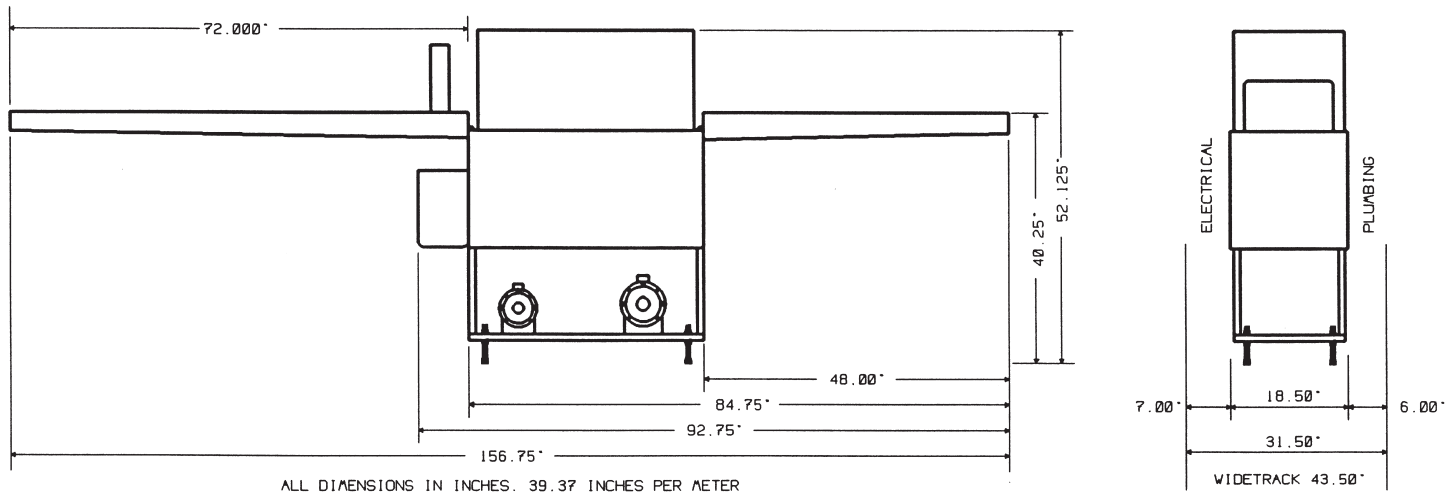

STANDARD FEATURES

- Stainless steel TEFC pumps • Stainless steel heaters • Digital controls • High alarm • Low alarm • Emergency “shutdown” switch • TEFC conveyor motor • Hinged back top • 3/4” stainless conveyor shafting • No-lube bearings • Threaded plumbing on all valves and unions • Schedule 80 plumbing • Waterproof NEMA 4X electrical on main body • Total water filtration • Quat spray splash guard • Conveyor stop switch • Spare float switch and thermocouple • Complete set of spare fuses • Conveyor drains • Leveling pads on main body and conveyors • Circulated quat for heated quat at the nozzle • Guides for flats to go directly under quat nozzles • Quat nozzles are spaced according to type of flat used • Nozzles line up directly over eggs • Quat spray bar quickly removes for replacement to other configuration or cleaning • Electrical: 220 volt, 60Hz, draws 62 amps; 3-phase and 50Hz available

ELIMINATOR 1 OPTIONS

- 6’ or 8’ out/in conveyor • Blower/drier • NEMA 4X digital covers • Quick-change wash nozzles • Wide track system 22” (57 cm) wide chain • Longer out/in conveyors (special) • Left hand load

WARRANTY

Digital controllers — 3 years; all other components carry a full 1-year warranty from delivery date. All warranty items shipped freight prepaid next day air, Federal Express, or by other means to have replacement item delivered to customer by the next business day (USA); Saturday next-day air service included.

ELIMINATOR 2

All photos show right-hand machines

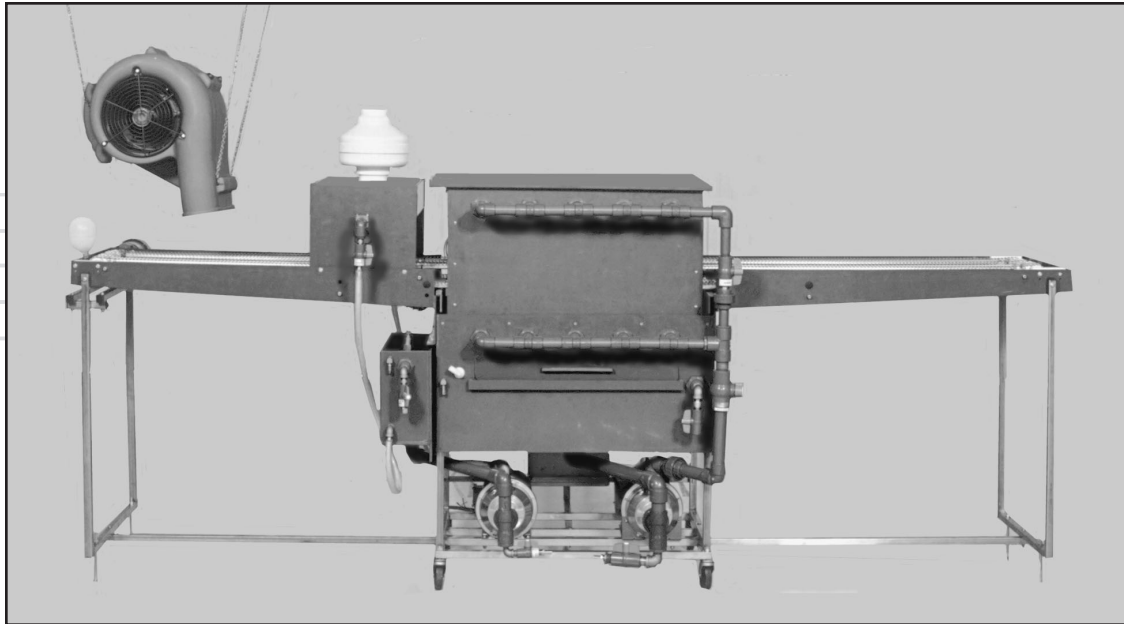

- 3/8" PVC construction • 15,000 to 25,000 breeders •
- 8,600 turkey/12,500 broiler/breeders eggs per hour •
- Standard model up to 13" (15 cm) flats • 4' incoming/ 6' outgoing conveyors •
- Wide track available accepts flats up to 24" (26 cm) wide •

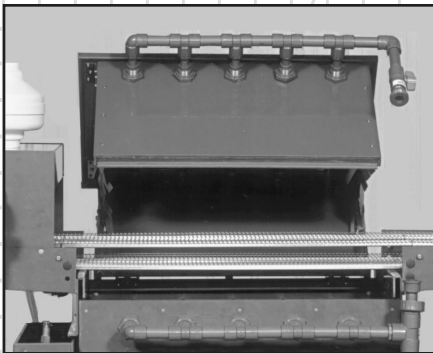

- Our exclusive rear-hinged top
- Easy access

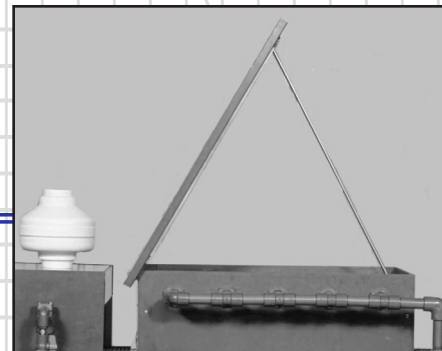

- Our exclusive top hinge
- Easy access



- Control panel
- Mount where you please
- Uses relay logic that is very simple and very reliable
- Pilot lights on all functions that diagnose outputs and operations

ELIMINATOR 2

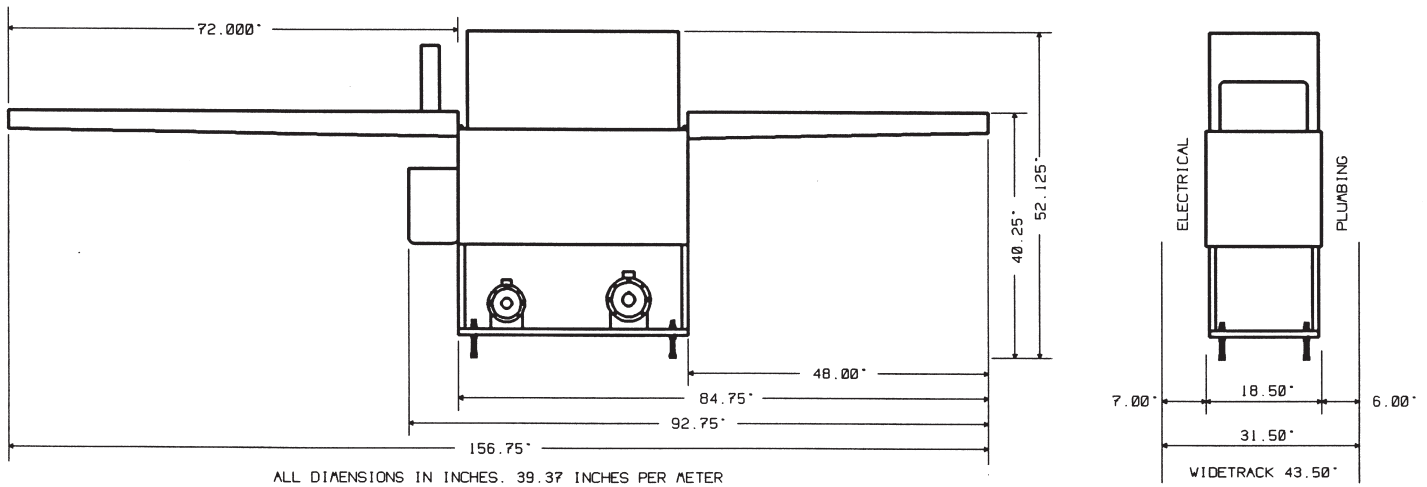

STANDARD FEATURES

- Stainless steel TEFC pumps • Stainless steel heaters • Digital controls • High alarm • Low alarm • Emergency "shutdown" switch • TEFC conveyor motor • Hinged back top • 3/4" stainless conveyor shafting • No-lube bearings • Neon blown-fuse indicator • Threaded plumbing on all valves and unions • Schedule 80 plumbing • Waterproof NEMA 4X electrical on main body • Total water filtration • Quat spray splash guard • Conveyor stop switch • Spare float switch and thermocouple • Complete set of spare fuses • Conveyor drains • Leveling pads on main body and conveyors • Circulated quat for heated quat at the nozzle • Guides for flats to properly line up under quat nozzles • Quat nozzles are spaced according to type of flat used • Nozzles line up directly over eggs • Quat spray bar quickly removes for replacement to other configuration or cleaning • Electrical: 220 volt, 60Hz, draws 62 amps; 3-phase and 50Hz available

ELIMINATOR 2 OPTIONS

- 6' or 8' out/in conveyor • Blower/drier • NEMA 4X digital covers • Vented hoods • Quick-change wash nozzles • Wide track system 22" (57 cm) wide chain • Longer out/in conveyors (special) • Left hand load

WARRANTY

Digital controllers — 3 years; all other components carry a full 1-year warranty from delivery date. All warranty items shipped freight prepaid next day air, Federal Express, or by other means to have replacement item delivered to customer by the next business day (USA); Saturday next-day air service included.

EXCLUSIVE FEATURES:

WHAT WE DO THAT OTHERS DON'T:

PROOF:

WE DO BUILD THE BEST!

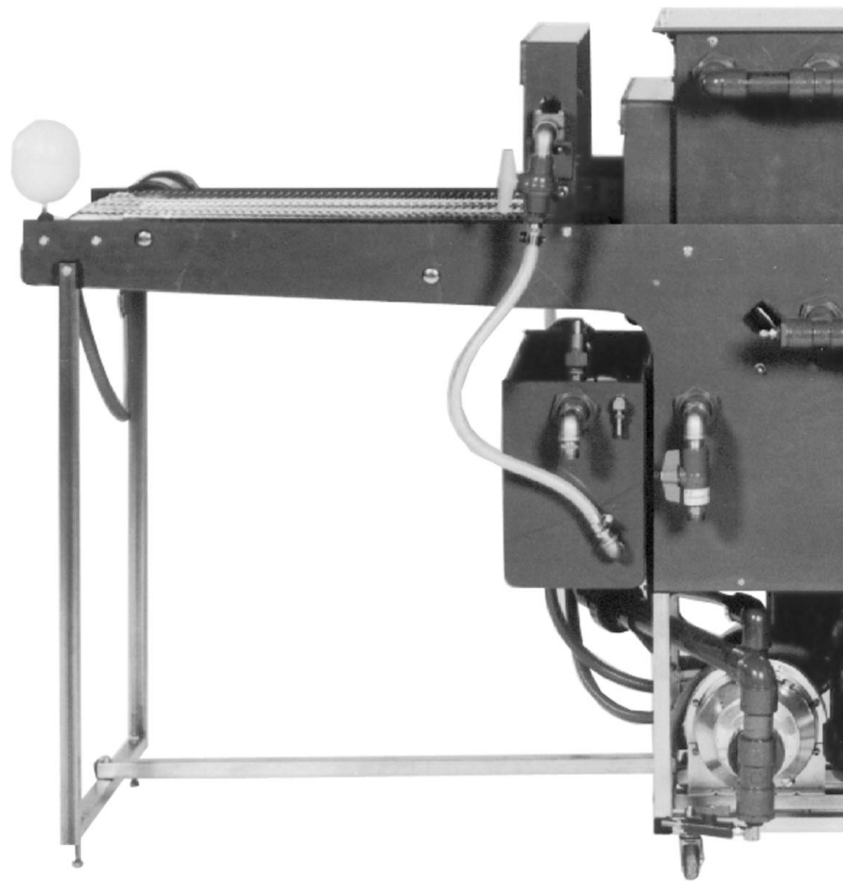
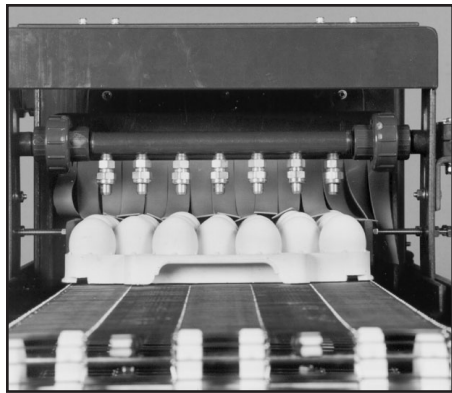

SCREWED AND WELDED BODY:

Superior to "welded only" for strength and longevity.

2 WATER FILTERS:

What our filter tray misses our "Y" filter gets. No clogged nozzles.

RIGHT OR LEFT HAND MODELS:

Offers the best usage of space and ergonomics of your egg room.

EGG FLAT GUIDE:

Aligns egg flats directly under quat spray. Each egg, every time gets a full coverage of quat.

MATCHED QUAT NOZZLES:

Positioned above each row of eggs Easily removes with no tools for changing to different egg flat types.

QUAT FILTER:

Helps to prevent these misting nozzles from clogging.

CHEMICAL METERING SYSTEM:

The most cost effective method of chemical usage. Actually reads the level of chemicals. Maintains same levels for the most economical usage of wash detergent.

SAFER AND COST EFFECTIVE:

OUR CUSTOMERS HAVE PROVEN THAT OUR "EGG CAPS" WASH DETERGENT IS AS EFFECTIVE AS CHLORINE BASED DETERGENTS!

NAMES YOU TRUST: PRODUCTS THAT LAST

**Omron · Potter & Brumfield · Grainger · Goulds Pump · Micro Switch · Phoenix Connectors
Tempco · Wire Belt · Carlon Electrical Enclosures and Fittings · Spears Schedule 80 PVC Plumbing
G.F. Valves · Spraying Systems Inc. · Dialight · Furnace · Little Fuse · Carol Wire
· Bee Valve · Diversylever · Stainless Steel · PVC · UHMW · Delrin · Dow Corning**

WE ARE JUST ONE OF OVER 400 STOCKING DISTRIBUTORS OF OUR COMPONENTS

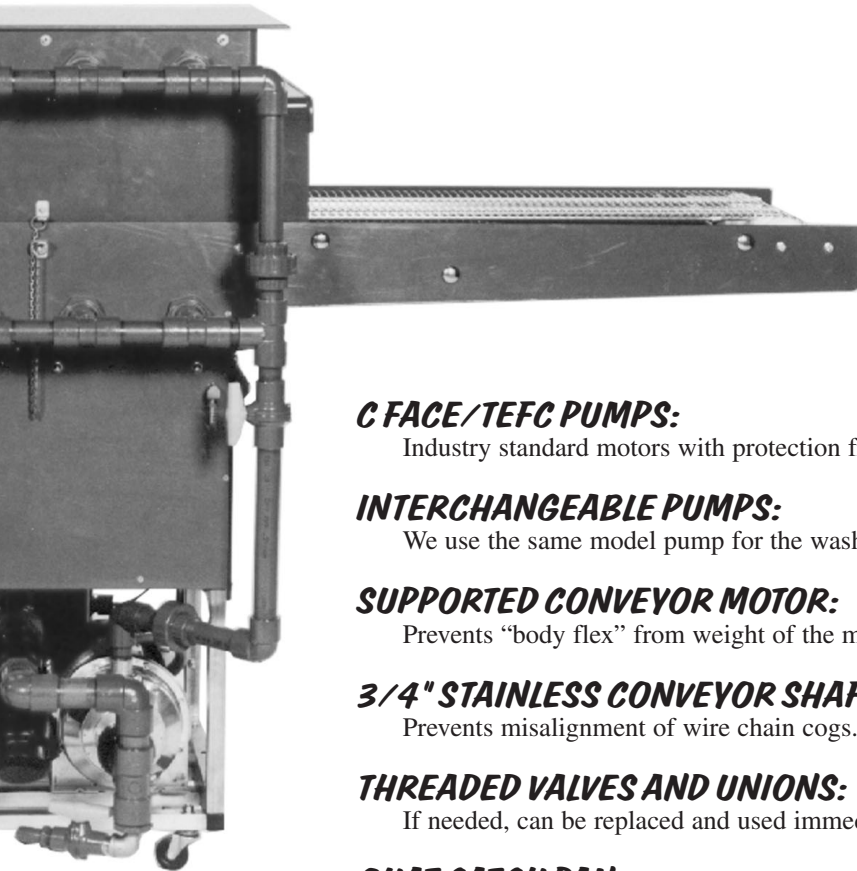

C FACE/TEFC PUMPS:

Industry standard motors with protection from water damage. Rebuildable motor and pump heads.

INTERCHANGEABLE PUMPS:

We use the same model pump for the wash and sanitize systems.

SUPPORTED CONVEYOR MOTOR:

Prevents "body flex" from weight of the motor and future alignment problems.

3/4" STAINLESS CONVEYOR SHAFTING:

Prevents misalignment of wire chain cogs.

THREADED VALVES AND UNIONS:

If needed, can be replaced and used immediately. No glue to dry.

QUAT CATCH PAN:

Prevents quat from re-entering the wash water.

FLOATING FRAME:

Eliminates stress on the body.

ALL NEMA 4X ELECTRICAL:

Protects electrical from water damage and makes clean up easy.

WARRANTY:

Digital Controllers - 3 years; all other components 1 year from delivery. Items shipped freight prepaid by UPS next day air service or other means to have replacement item delivered by the next business day (USA/CAN.), Saturday included.

ELIMINATOR 3B

All photos show right-hand machines

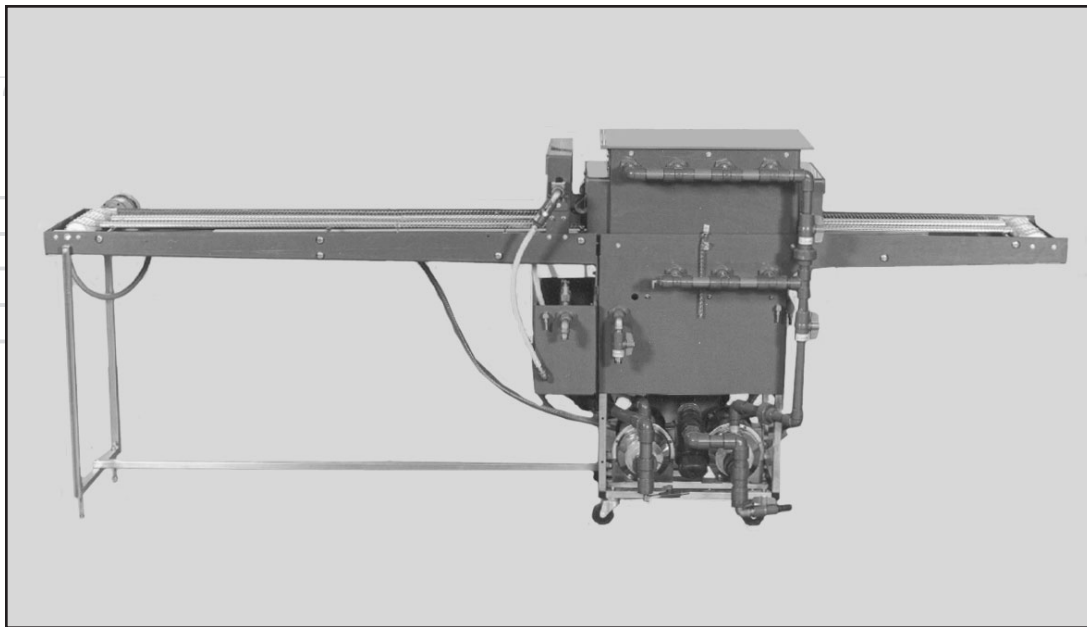

- 3/8" PVC construction • 9,000 to 15,000 breeders •
- 6,200 turkey/9,000 broiler/breeders eggs per hour •
- 13" (15 cm) flats • 3' incoming/ 4' outgoing conveyor •
- Variable clean room conveyor lengths •

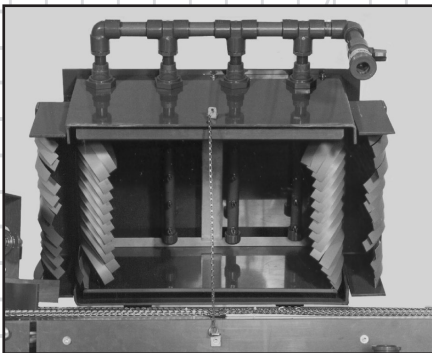

- Our exclusive rear-hinged top
- Easy access

- Our exclusive top hinge
- Easy access

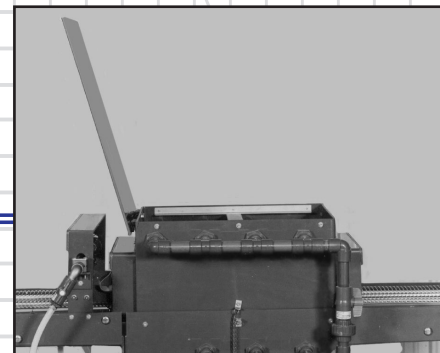

- Control panel
- Mount where you please
- Uses relay logic that is very simple and very reliable
- Pilot lights on all functions that diagnose outputs and operations



ELIMINATOR 3B

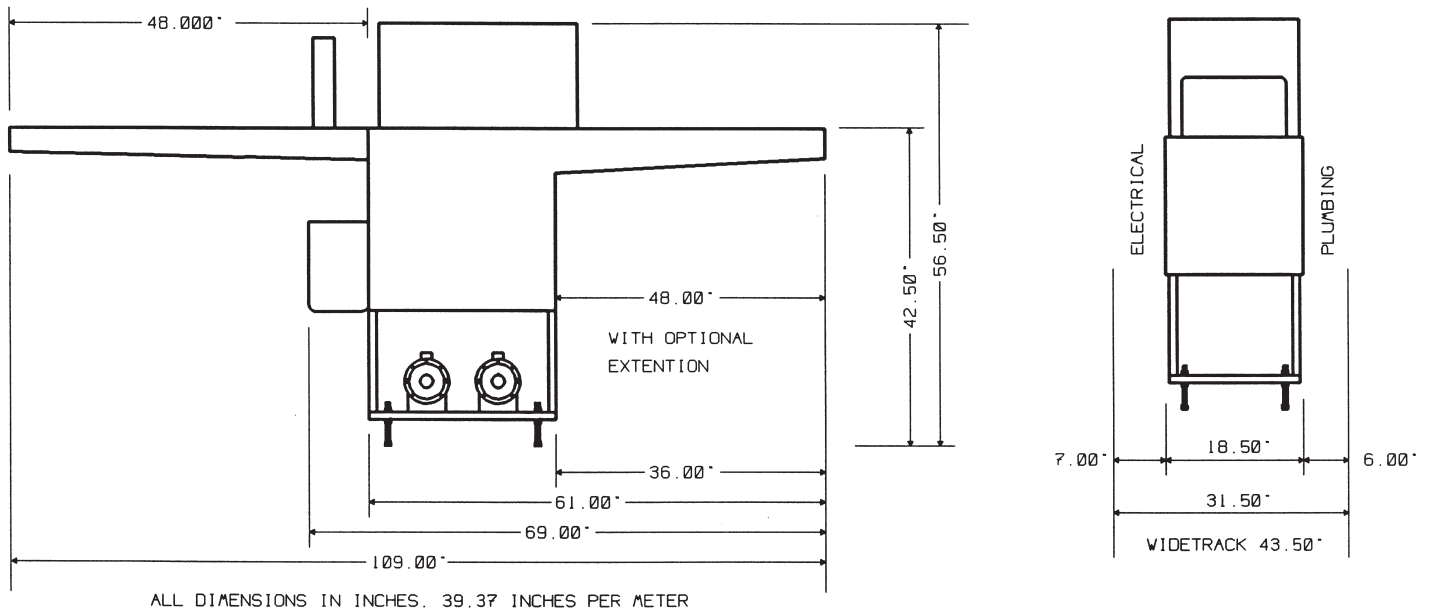

STANDARD FEATURES

- Stainless steel TEFC pumps • Stainless steel heaters • Digital controls • High alarm • Low alarm • Emergency “shutdown” switch • TEFC conveyor motor • Hinged back top • 3/4” stainless conveyor shafting • No-lube bearings • Threaded plumbing on all valves and unions • Schedule 80 plumbing • Waterproof NEMA 4X electrical on main body • Total water filtration • Quat spray splash guard • Conveyor stop switch • Spare float switch and thermocouple • Complete set of spare fuses • Conveyor drains • Leveling pads on main body and conveyors • Circulated quat for heated quat at the nozzle • Guides for flats to properly line up under quat nozzles • Quat nozzles are spaced according to type of flat used • Nozzles line up directly over eggs • Quat spray bar quickly removes for replacement to other configuration or cleaning •
- Electrical: 220 volt, 60Hz, draws 62 amps; 3-phase and 50Hz available

ELIMINATOR 3 OPTIONS

- 6’ or 8’ out conveyor • Blower/drier • NEMA 4X digital covers • Neon lighted blown fuse indicators • Quick-change wash nozzles • Wide track system 22” (57 cm) wide conveyor chain • Longer outgoing conveyors (special) • Left hand load

WARRANTY

Digital controllers — 3 years; all other components carry a full 1-year warranty from delivery date. All warranty items shipped freight prepaid next day air, Federal Express, or by other means to have replacement item delivered to customer by the next business day (USA); Saturday next-day air service included.

ELIMINATOR 3B4

All photos show right-hand machines

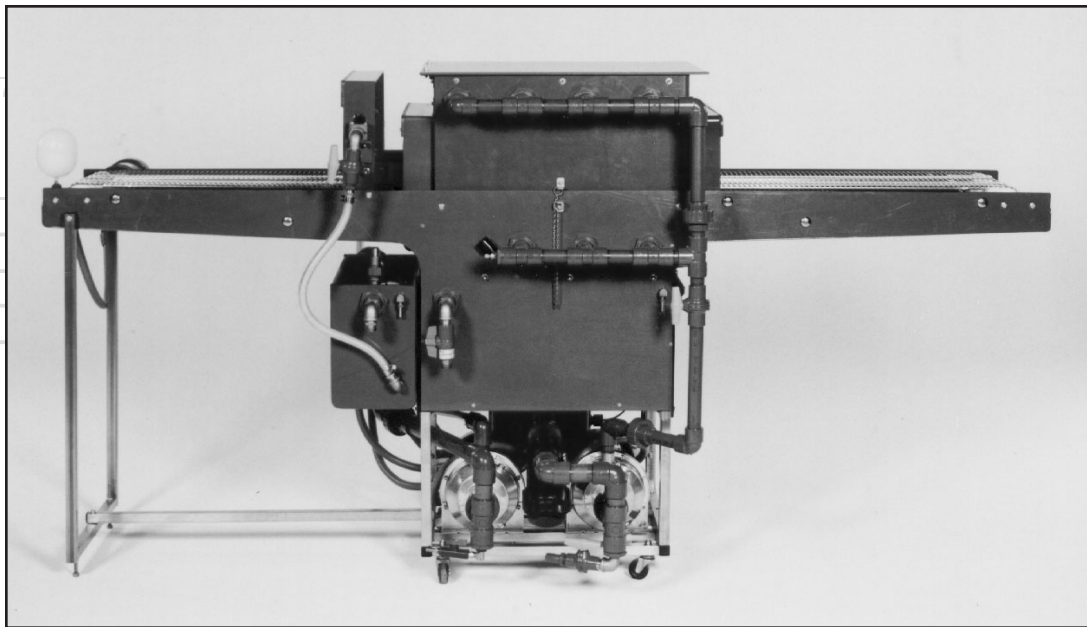

- 3/8" PVC construction • 9,000 to 15,000 breeders •
- 6,200 turkey/9,000 broiler/breeders eggs per hour •
- 13" (15 cm) flats • 3' incoming/ 3' outgoing conveyor •
- Fixed conveyor lengths •

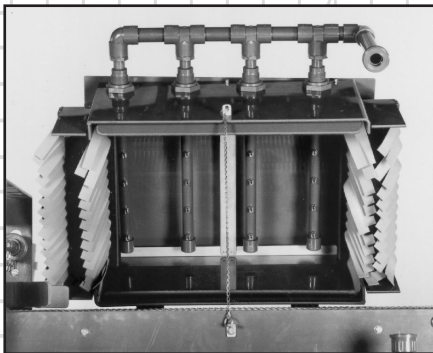

- Our exclusive rear-hinged top
- Easy access

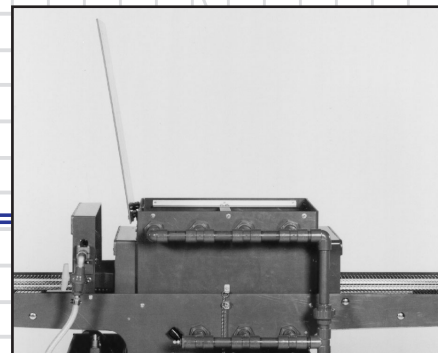

- Our exclusive top hinge
- Easy access



- Control panel
- Mount where you please
- Uses relay logic that is very simple and very reliable
- Pilot lights on all functions that diagnose outputs and operations

ELIMINATOR 3B4

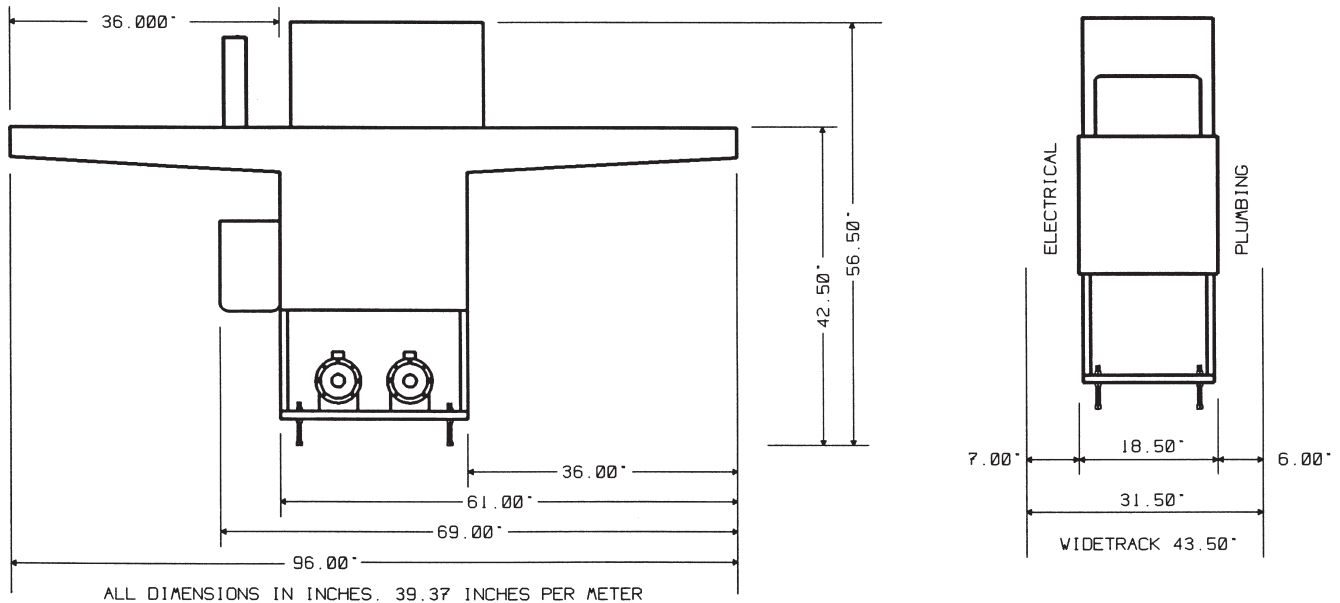

STANDARD FEATURES

- Stainless steel TEFC pumps • Stainless steel heaters • Digital controls • High alarm • Low alarm • Emergency "shutdown" switch • TEFC conveyor motor • Hinged back top • 3/4" stainless conveyor shafting • No-lube bearings • Threaded plumbing on all valves and unions • Schedule 80 plumbing • Waterproof NEMA 4X electrical on main body • Total water filtration • Quat spray splash guard • Conveyor stop switch • Spare float switch and thermocouple • Complete set of spare fuses • Conveyor drains • Leveling pads on main body and conveyors • Circulated quat for heated quat at the nozzle • Guides for flats to properly line up under quat nozzles • Quat nozzles are spaced according to type of flat used • Nozzles line up directly over eggs • Quat spray bar quickly removes for replacement to other configuration or cleaning • Electrical: 220 volt, 60Hz, draws 62 amps; 3-phase and 50Hz available

ELIMINATOR 3 OPTIONS

- 6' or 8' out/in conveyor • Blower/drier • NEMA 4X digital covers • Neon lighted blown fuse indicators • Quick-change wash nozzles • Wide track system 22" (57 cm) wide conveyor chain • Longer outgoing conveyors (special) • Left hand load

WARRANTY

Digital controllers — 3 years; all other components carry a full 1-year warranty from delivery date. All warranty items shipped freight prepaid next day air, Federal Express, or by other means to have replacement item delivered to customer by the next business day (USA); Saturday next-day air service included.

ELIMINATOR 4B

All photos show right-hand machines

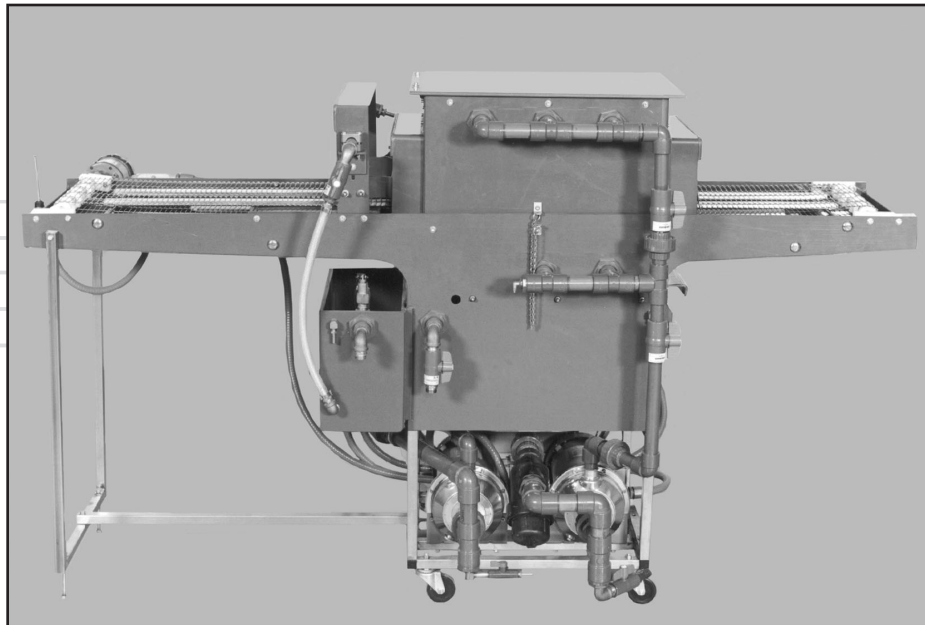

- 3/8" PVC construction • Up to 9,000 breeders •
- 3,187 turkey/5,500 broiler/breeders eggs per hour •
- 13" (15 cm) flats • 2' incoming/3' outgoing •
- Fixed conveyor lengths •

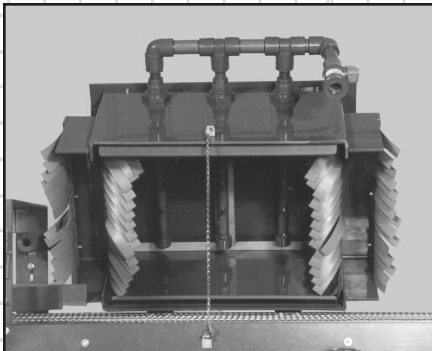

- Our exclusive rear-hinged top
- Easy access

- Our exclusive top hinge
- Easy access

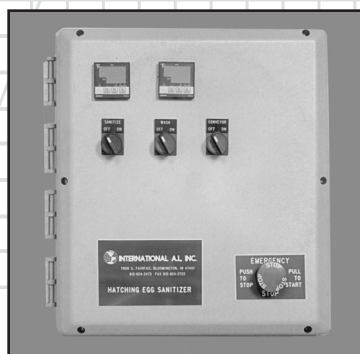
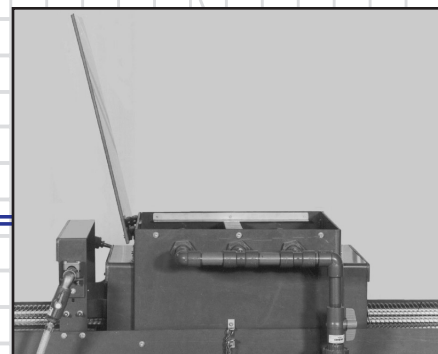

- Control panel
- Mount where you please
- Uses relay logic that is very simple and very reliable
- Uses the same components as our larger models

ELIMINATOR 4B

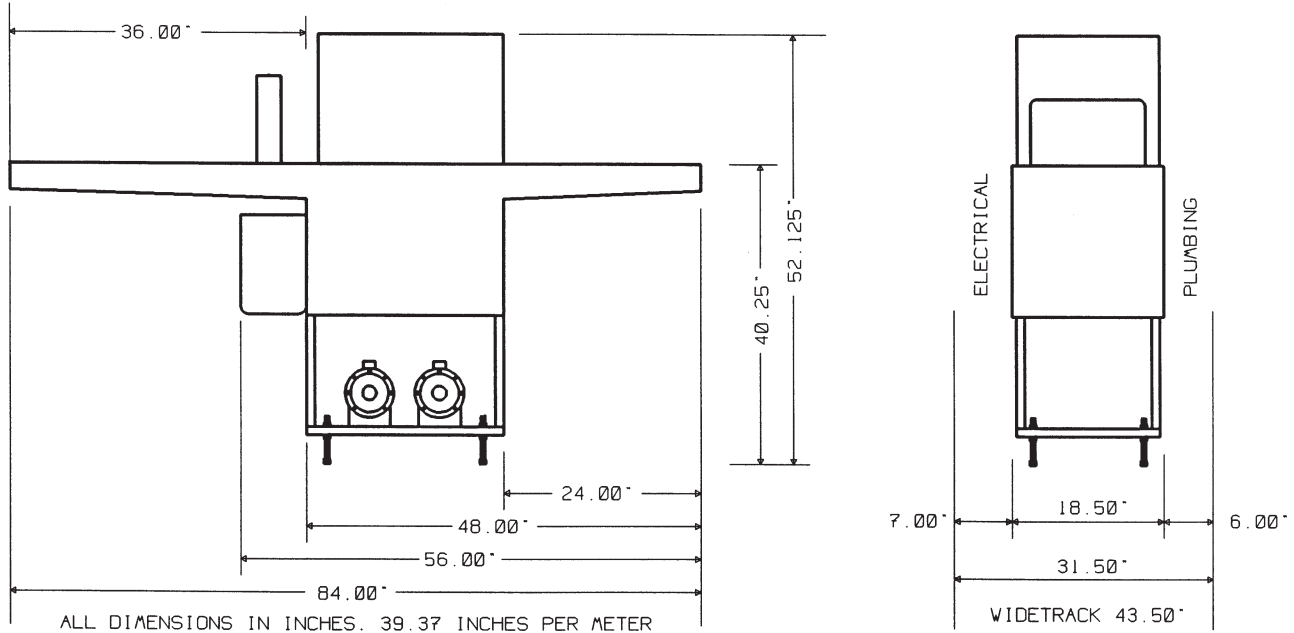

STANDARD FEATURES

- Stainless steel TEFC pumps • Stainless steel heaters • Digital controls • High alarm • Low alarm • Emergency “shutdown” switch • TEFC conveyor motor • Hinged back top • 3/4” stainless conveyor shafting • No-lube bearings • Threaded plumbing on all valves and unions • Schedule 80 plumbing • Waterproof NEMA 4X electrical on main body • Total water filtration • Conveyor stop switch • Quat spray splash guard • Spare float switch and thermocouple • Complete set of spare fuses • Conveyor drains • Leveling pads on main body • Circulated quat for heated quat at the nozzle • Guides for flats to properly line up under quat nozzles • Quat nozzles are spaced according to type of flat used • Nozzles line up directly over eggs • Quat spray bar quickly removes for replacement to other configuration or cleaning • Electrical: 220 volt, 60Hz, draws 62 amps; 3-phase and 50Hz available

ELIMINATOR 4 OPTIONS

- NEMA 4X digital covers • Neon lighted blown fuse indicators • Quick-change wash nozzles • Wide track system 22” (57 cm) wide conveyor chain • 1’ or 2’ conveyor extensions • Left hand load

WARRANTY

Digital controllers — 3 years; all other components carry a full 1-year warranty from delivery date. All warranty items shipped freight prepaid next day air, Federal Express, or by other means to have replacement item delivered to customer by the next business day (USA); Saturday next-day air service included.

We Offer a Complete Line Tailored For Your Needs

Our line of "ELIMINATOR" Hatching Egg Sanitizers can be tailored to fit your individual needs. Rest assured that International A.I., Inc. will have the proper equipment. Dependent upon which model and the type of egg flat that you will be using, capacities of up to 8,600 turkey or 12,500 chicken eggs per hour are obtainable. Each machine is matched with conveyor speed to the properly sized wash and rinse nozzles to ensure that while we increase capacities, we do not decrease the longevity of the equipment from an improperly designed system. From recycled wash water to our "recharged" system, from 3,200 to 12,500 eggs per hour, to our blower/driers, we have the equipment that suits you.

Don't settle for less — have what you need, not "what they sold me."

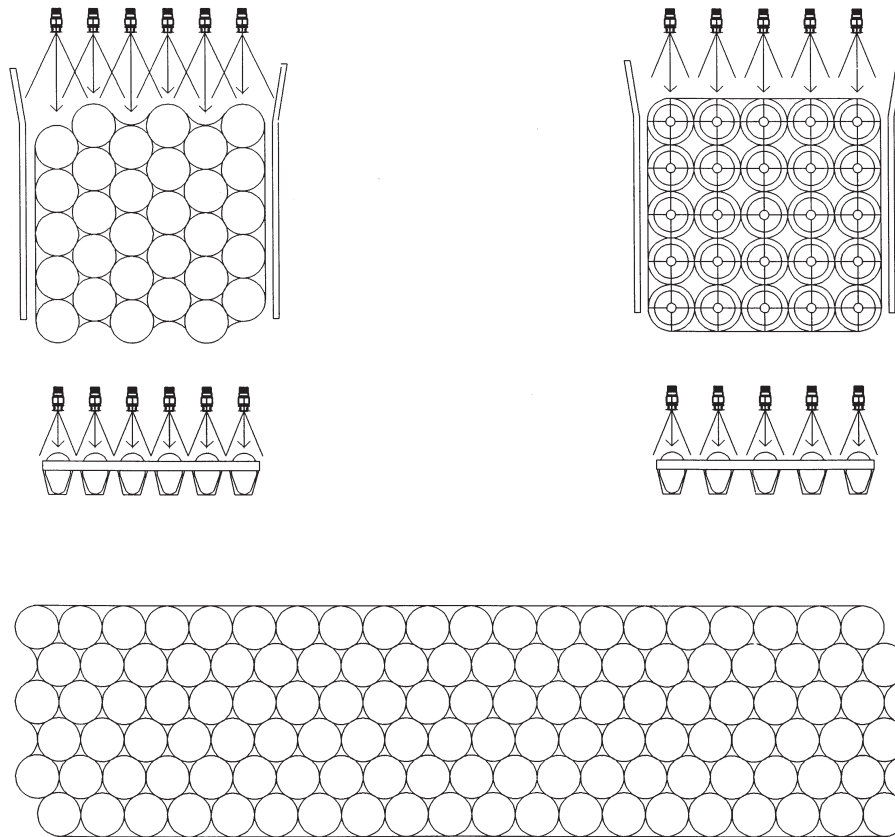

The only egg sanitizer engineered from the inside out

The Sign for Quality

"WHERE THE SUM OF THE PARTS ALWAYS EQUALS THE WHOLE"

Q + U + A + L + I + T + Y = QUALITY